

SHEAR-WEB FORCE LOAD CELL

MEG40



Special features

- For general purpose
- Strain gauge measuring system
- Tension / Compression
- Made of high-grade stainless steel
- Low profile
- With build-in amplifier
(option – see datasheet MEG41)

Specifications

Rated capacity (F _n)	1, 2, 5	10, 20, 50	kN
Overload			
- Safe	130		% F _n
- Ultimate	150		% F _n
- Permanent static load ¹	75		% F _n
- Dynamic load ¹	50		% F _n
Nominal sensitivity (C _n)	1.5 ± 2 %		mV/V
Zero balance	2		% F.S.
Non-linearity	0.25	0.5	% F.S.
Hysteresis	0.25	0.5	% F.S.
Creep (30 min)	0.1		% F.S.
Temperature effect			
- On zero	0.1		% F.S./10 °C
- On output	0.1		% F.S./10 °C
Bridge resistance			
- Input	380 ± 10 %		Ω
- Output	350 ± 5 %		Ω
Insulation Impedance	> 500		MΩ
Excitation ²			
- Recommended	7 ... 10		V
- Maximal	15		V
Temperature range			
- Compensated	0 ... + 50		°C
- Operating	- 10 ... + 70		°C
Protection	IP54		
Cable			
- Type	LifYDY 4 x 0.05	LiYCY 4 x 0.14	
- Length	2	2	m

Notes:

- 1 Recommended value
2 DC or AC Voltage

Outline dimensions

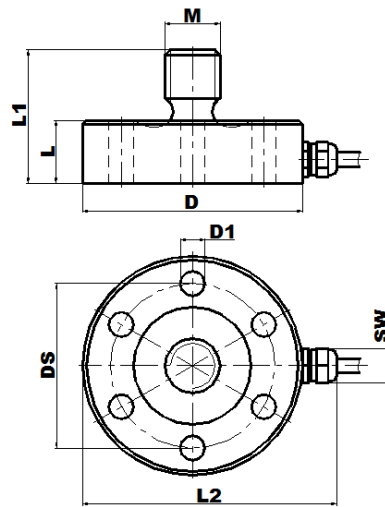

Rated capacity F_n (kN)	D mm	D1 mm	L mm	L1 mm	L2 mm	M mm	SW mm	DS mm	Mass kg	Deflection, @ F_n (μm)
1	38	6x4.2	11	22	46	M8	Φ 4	30	0.07	30
2	38	6x4.2	11	22	46	M8	Φ 4	30	0.07	30
5	38	6x4.2	11	22	46	M8	Φ 4	30	0.08	35
10	50	6x5.2	14	29	58	M10	8	38	0.18	45
20	56	6x6.3	16	34	64	M14	8	42	0.27	50
50	68	6x8.4	19	42	76	M20	8	50	0.50	65

Sensor wiring colour code

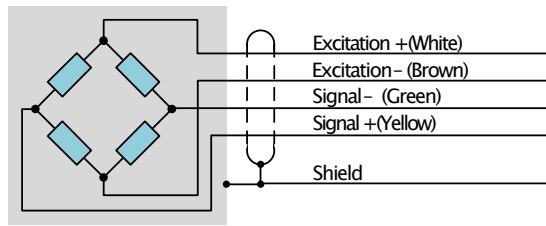

Sensor output characteristic

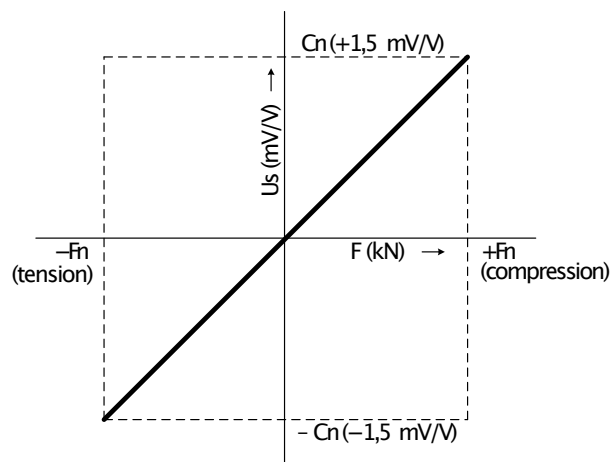

Wiring diagrams, connection examples to EMS169 signal conditioner

1. Load COMPRESSION, signal conditioner output positive (0...+10 V, 4...20 mA)

Links setting

J2 = ON, J3 = ON, J4 = 2 – 3 (connected)

Wiring diagram

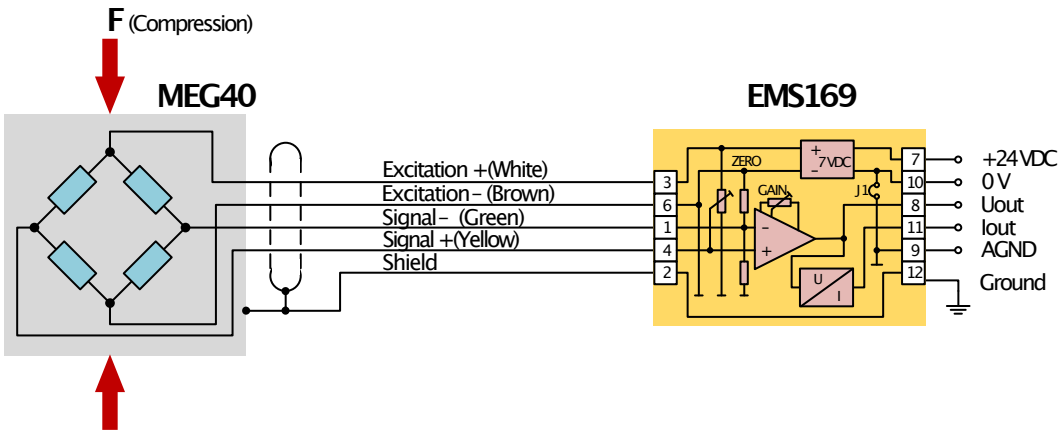

System output characteristic

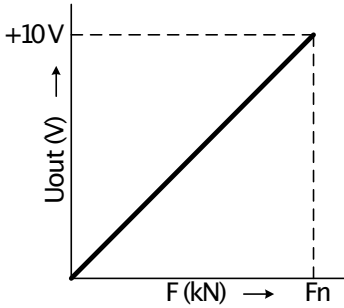

Uout vs. F

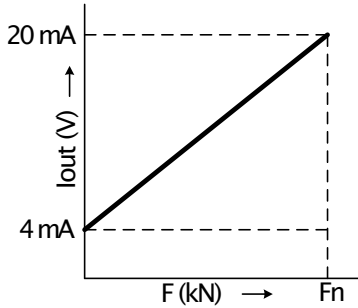

Iout vs. F

2. Load TENSION, signal conditioner output positive (0...+10 V, 4...20 mA)

Links setting

J2 = ON, J3 = ON, J4 = 2 – 3 (connected)

Wiring diagram

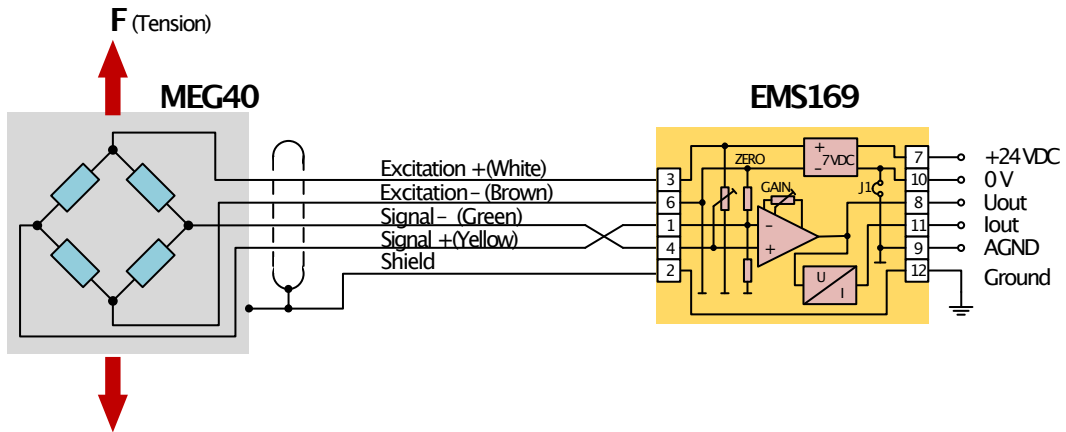

System output characteristic

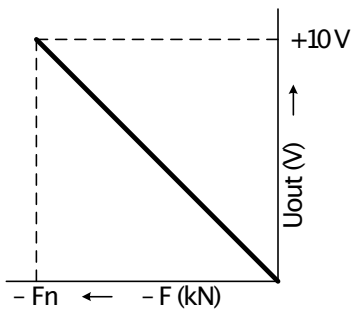

Uout vs. F

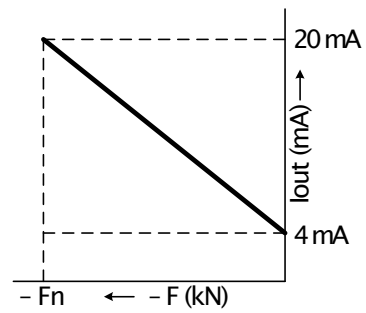

Iout vs. F

3. Load COMPRESSION and TENSION, signal conditioner output bipolar (- 10 V ... 0...+ 10 V)

Note: The current output does not work in the negative range.

Links setting

J2 = ON, J3 = ON, J4 = 2 - 3 (connected)

Wiring diagram

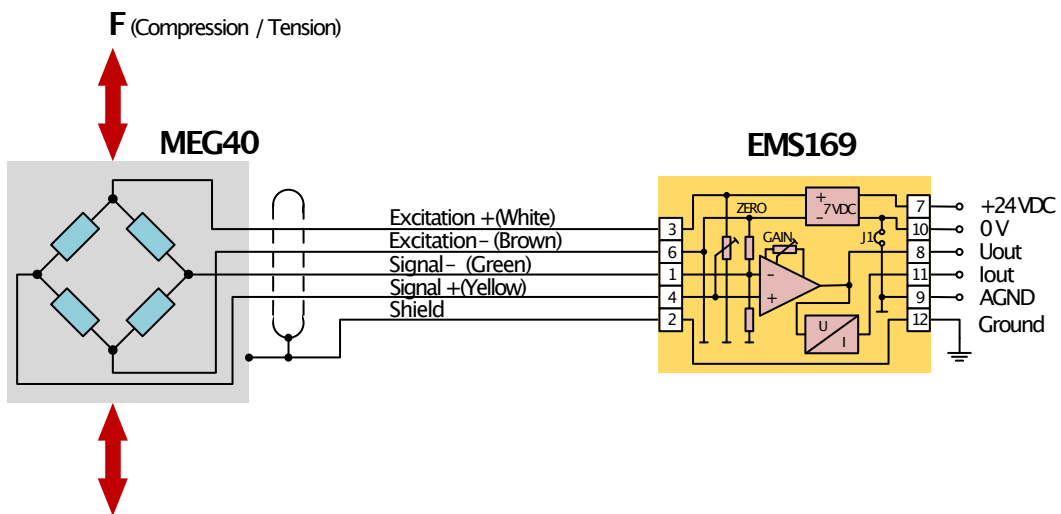

System output characteristic

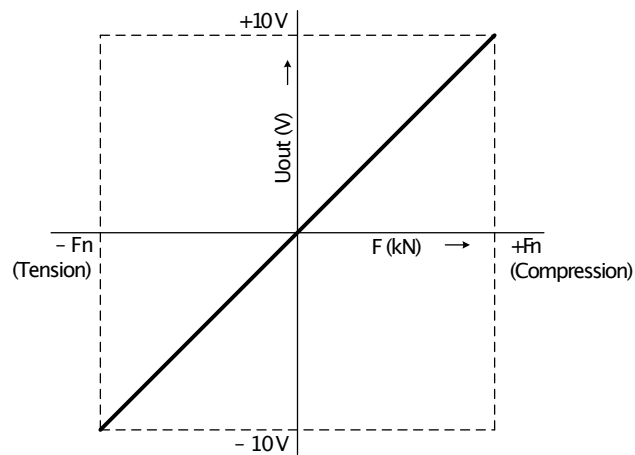

Uout vs. F

4. Load COMPRESSION and TENSION, signal conditioner output positive (0...+10 V, 4...20 mA)

Links setting

J2 = ON, J3 = OFF, J4 = 1 – 2 (connected)

Wiring diagram

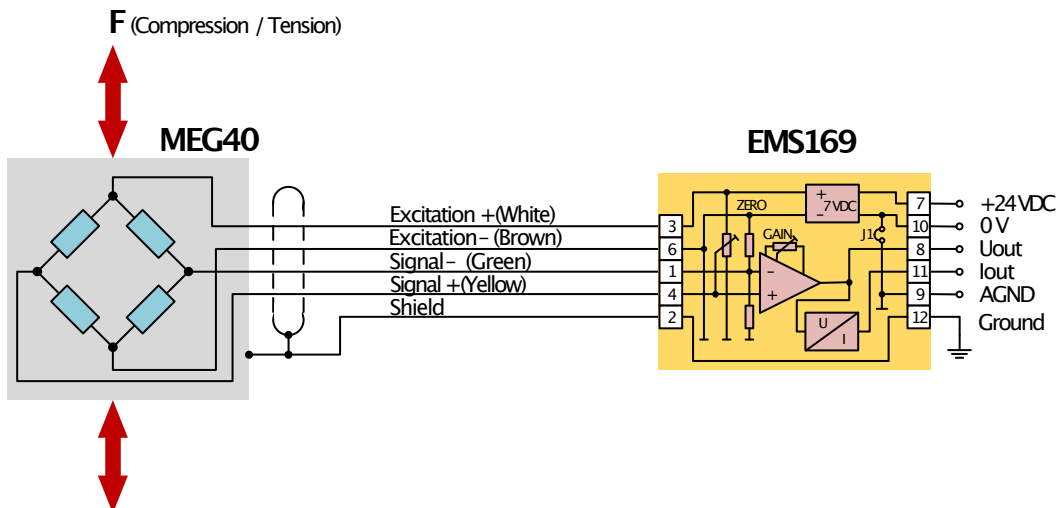

System output characteristic

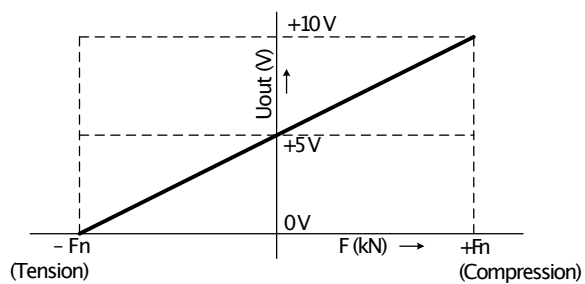

U_{out} vs. F

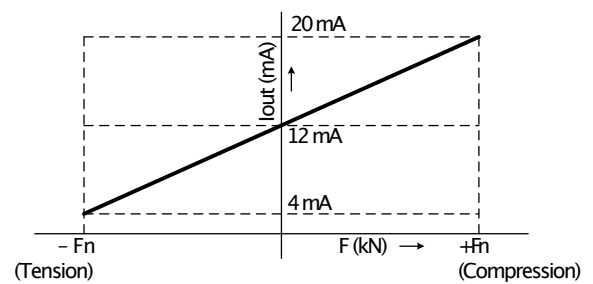

I_{out} vs. F

Parallel wiring diagram

