



Signal conditioner for SG sensors

EMS169

Version v3.1

Operating manual

Technical data

| | |
|--|--|
| Accuracy class | 0,2 |
| Input - Strain Gauge Sensor (Force, Pressure, Moment), Sensitivity | 0,8 ... 2,3 mV/V |
| Sensor Excitation - Voltage - Min. sensor impedance | 7 VDC 300 Ω |
| Voltage Output - Bipolar - Bipolar "Low" - Bipolar with zero offset - Min. load impedance | 0 ... \pm 10 V 0 ... \pm 5 V 5 ... \pm 5 V 2 k Ω |
| Current Output - Unipolar - Bipolar with zero offset - Max. load impedance | 4 ... 20 mA 12 ... \pm 8 mA 500 Ω |
| Amplifier - Zero adjustment - Input offset voltage drift - Thermal sensitivity drift - Non-linearity | 0 ... \pm 2,5 V 1 μ V / $^{\circ}$ C 100 ppm / $^{\circ}$ C 0,05 % FS |
| Butterworth Low Pass Filter 2nd Order - Frequency range "Low" - Frequency range "High" | 20 Hz 1 kHz |
| Power Supply - Range - Max. current consumption | 24 VDC \pm 10 % 50 mA |
| Temperature Range - Operating - Storage | - 10 ... + 50 $^{\circ}$ C - 40 ... + 85 $^{\circ}$ C |

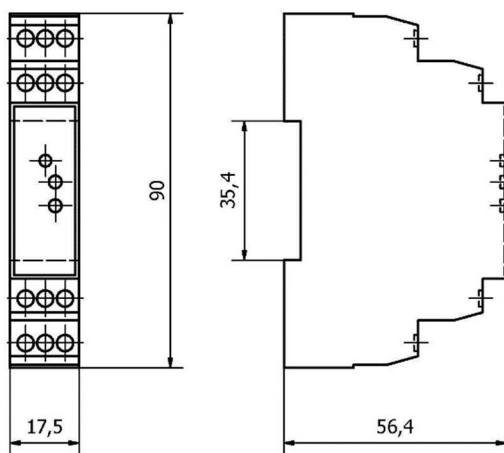

Fig. 1. Outline dimensions (mm)

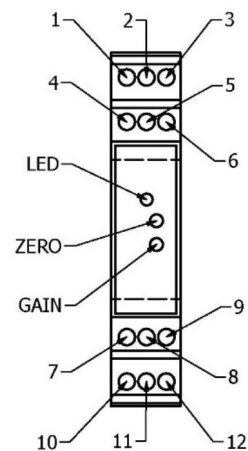

Fig. 2. Clamps layout

Mechanical Installation

The signal conditioner EMS169 was designed for installation onto DIN rail, in closed metallic housing, e.g. control cabinet. Do not install it near contactors, power lines etc. because of strong electromagnetic interference. To ensure safe operation use it according to the specifications given in this manual, e. g. ambient temperature. The working position is arbitrary.

Connection

The EMS169 has two outputs: voltage and current. Depending on which output is used, connect the module according to fig. 3 (voltage output) or fig. 4 (current output). It is also possible to use both outputs simultaneously, however with the trimmer „ZERO“ (or „GAIN“) it is possible to adjust just one output only.

The module is delivered with the link J1 = ON (see fig 5). It means that the signal ground and power ground are connected. In most cases this configuration is convenient. If it is necessary to separate the signal and power grounds, disconnect the J1 link. However, note that to suppress the electromagnetic interference just disconnecting J1 link is usually not sufficient. There are other techniques to be used for example shielded cables, close the device onto metallic box etc.

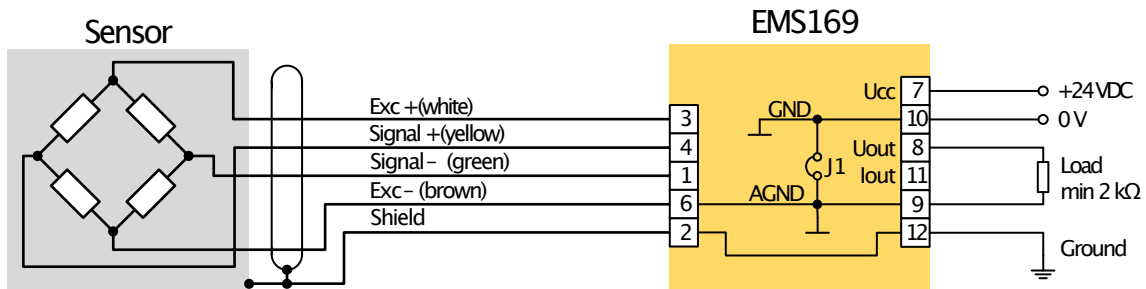

Fig. 3. Wiring diagram, voltage output.

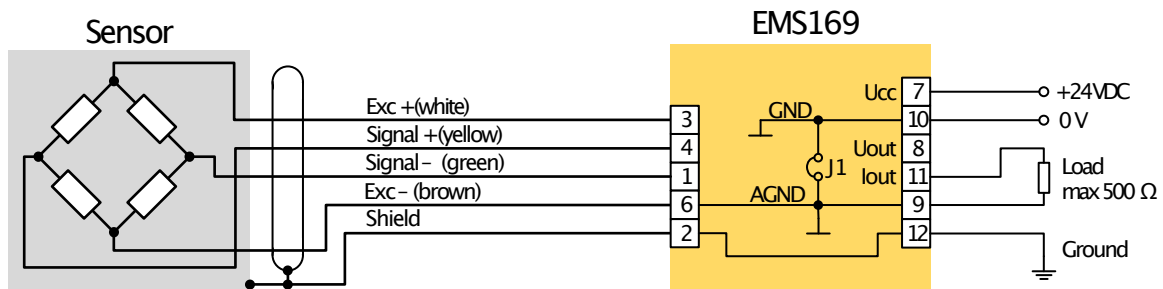

Fig. 4. Wiring diagram, current output.

Notice: This wire colours apply to sensors made by EMSYST only!

Outputs configuration

For configuration open the housing with small screwdriver. Configuration is performed using links J2, J3 and J4, located on the printed circuit board. Three voltage and two current outputs can be set. However the input sensor sensitivity must be also taken into account. See the link settings in tab 1. The link J4 has three pins. It is not possible to remove this link, pins 1 – 2 or 2 – 3 must be always connected.

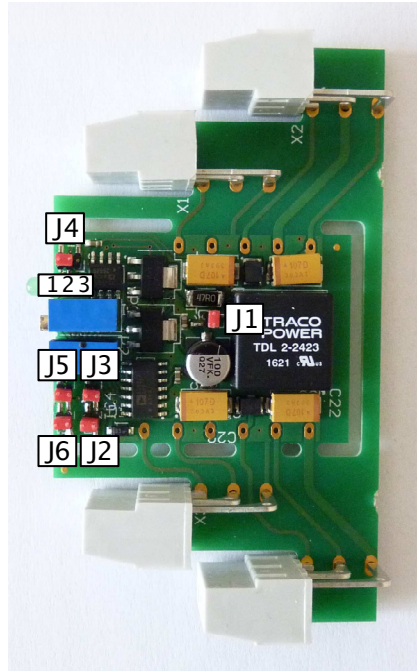

Fig. 5. Links location on the printed circuit board.

Tab. 1. Outputs configuration

| Output range | Max. input sensor sensitivity mV/V | Links setting | | |
|---|------------------------------------|---------------|-----|-------|
| | | J2 | J3 | J4 |
| 0 V ... +10 V | 0.8 ... 2.1 | ON | ON | 2 – 3 |
| + 4 mA ... + 20 mA | 1.7 ... 3.0 | OFF | ON | 2 – 3 |
| –10 V ... 0 V ... +10 V | 0.8 ... 2.1 | ON | ON | 2 – 3 |
| | 1.7 ... 3.0 | OFF | ON | 2 – 3 |
| –5 V ... 0 V ... +5 V | 0.4 ... 1.0 | ON | ON | 2 – 3 |
| | 0.9 ... 1.45 | OFF | ON | 2 – 3 |
| | 1.3 ... 1.85 | ON | OFF | 2 – 3 |
| | 1.8 ... 2.3 | OFF | OFF | 2 – 3 |
| 0V ... + 5V ... + 10V + 4 mA ... + 12 mA ... + 20 mA (Zero offset output) | 0.4 ... 1.0 | ON | ON | 1 – 2 |
| | 0.9 ... 1.45 | OFF | ON | 1 – 2 |
| | 1.3 ... 1.85 | ON | OFF | 1 – 2 |
| | 1.8 ... 2.3 | OFF | OFF | 1 – 2 |

Filter configuration

Active filter of 2nd order (Butterworth characteristic) is built-in into the EMS169. The filter can be modified with links J5 and J6, see the table 2. Use the standard bandwidth of 0 ... 20 Hz for common applications. The bandwidth 1000 Hz is used for fast applications only, for example for regulating loops.

Tab. 2. Filter configuration

| Bandwidth in Hz (- 3 dB) | Links setting | |
|------------------------------|---------------|-----|
| | J5 | J6 |
| 0 ... 20 Hz | OFF | OFF |
| 0 ... 1000 Hz | ON | ON |

Calibration

The goal of the calibration is to set up the signal conditioner so that output signal corresponds to the input force. If we have for example sensor with measuring range 0 ... 5 kN and output signal is configured for 4 ... 20 mA (fig. 6) then, at load 0 kN (unloaded sensor) the output signal has to be 4 mA, and at load 5 kN 20 mA.

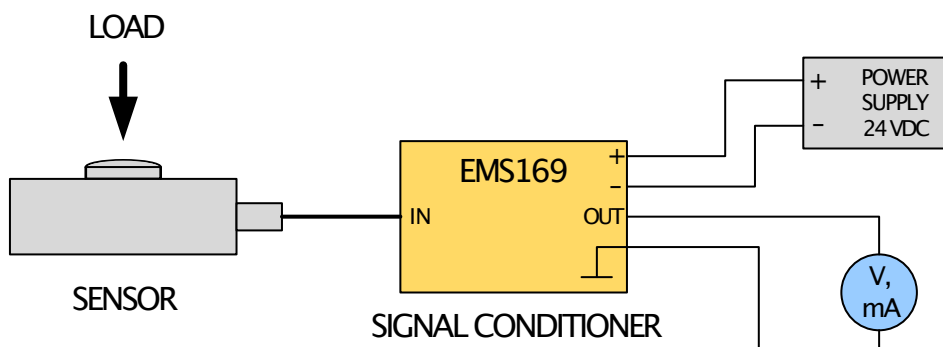

Fig. 6. Calibration connecting

As an example for calibration we take sensor EMS20-5 kN and signal conditioner EMS169 with the current output configured for 4 ... 20 mA.

Adjustment

1. Configure the EMS169 (J2 = J3 = ON, J4: 2 – 3 is ON) and connect it according to fig. 4.
2. Release the sensor and adjust the trimmer „ZERO“ to 4 mA.
3. Load the sensor with 5 kN and adjust the trimmer „GAIN“ to 20 mA.
4. Verify the zero point (step 2). If it is necessary, repeat the steps 2 and 3 until the both points „ZERO“ and „GAIN“ are correct.

Notice1. Sometime you can't load the sensor with nominal value. Then you have to calculate the output signal.

Formula

$$\left(\frac{\text{---}}{\text{---}} \right) * \left(\text{---} \right) + \left(\text{---} \right)$$

Example: If we can't load the sensor with 5 kN but only with 2 kN then the output signal is:

$$= \frac{2}{5} * 16 + 4 = 10,4$$

Notice2. If possible, use a nominal load or load near to nominal value. This increases the accuracy of calibration.

Factory setting

The producer delivers signal conditioner EMS169 configured as follows (unless the customer ordered other setting):

- Sensor sensitivity 1,5 mV/V
- Output – 10 V ... + 10 V / 4 ... 20 mA
- Filter 0 ... 20 Hz
- Link J1 ON (power ground and signal ground are connected)

Guarantee and service

The guaranty period is two years since the purchase of the device. For a service during guaranty period contact the supplier or directly manufacturer:

MEGATRON,s.r.o. Mrštíkova 16,10000 Praha 10,

T.:+420274780972,info@megatron.cz, www.megatron.cz

Troubleshooting

If the system is not working properly, try the steps below (follow the sequence of steps). If the problem has not been solved, contact the supplier or manufacturer.

1. **Wiring control.** Check the correct connection of supply voltage (to be $24\text{ V} \pm 10\%$), and supply current – should not be greater than 50 mA. Disconnect output. The output measure always by a voltmeter or ammeter - the problem may also be in the input circuits of the device that processes the signal.
2. **Functionality test of the signal conditioner.** The correct function can be detected by a simple control. Configure the signal conditioner to bipolar voltage output - $10\text{V} \dots +10\text{V}$ ($J2 = J3 = \text{ON}$, $J4: 2 - 3 = \text{ON}$) and connect the power supply. No sensor is connected to the input. To the output connect voltmeter or amperemeter according to the type of output signal, see Fig. 7.

Notice. The voltmeter is shown in the figure 7. If the current output is used, the current must be also checked.

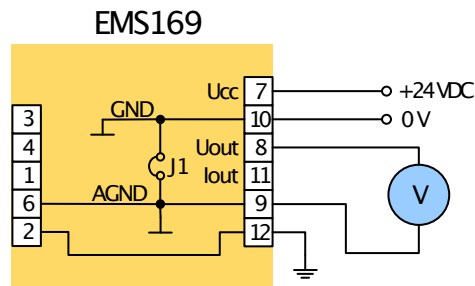

Fig. 7. Functionality test

Control procedure

- 2.1. Turn trimmer „GAIN“ and „ZERO“ to the left. The output voltage should be approximately – 13.5 V (current output – 0,2 mA).
- 2.2. Turn the trimmer „ZERO“ to the right and check the output voltage. The voltage should rise, to the value approximately + 13.5 V (current to 27 mA).
- 2.3. Set by the trimmer „ZERO“ a small positive voltage on the output, e.g. 0,5 V (or small current, e.g. 5 mA).
- 2.4. Increase the gain of the signal conditioner by turning of the trimmer „GAIN“ to the right. The voltage (current) should rise. After the test turn it back to the left.
- 2.5. Set by the trimmer „ZERO“ small negative voltage to the output, e.g. – 0,5 V.
- 2.6. Now, by turning of the trimmer „GAIN“ to the right the output voltage should sink.

If all steps are OK, the signal conditioner is probably OK too.

3. **Sensor excitation test 1 (without sensor)**. The excitation voltage of the sensor is measured at the clamps 3 and 6, see figure 8. It should be $+ 7.0 \text{ V} \pm 5 \text{ mV}$.

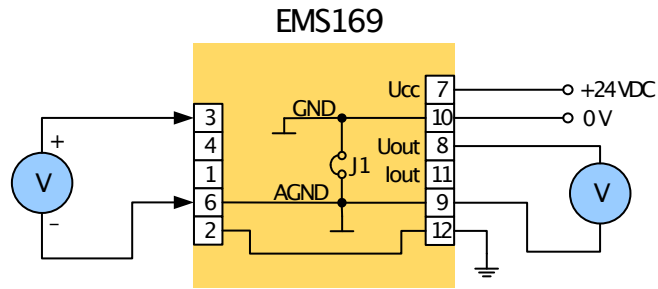

Fig. 8. Excitation sensor voltage measuring (without sensor)

4. **Sensor excitation test 2 (with sensor)**. Connect sensor to the signal conditioner according to figure 9. Measure again the excitation voltage at the clamps 3 and 6. It should be again $+ 7.0 \text{ V} \pm 5 \text{ mV}$.

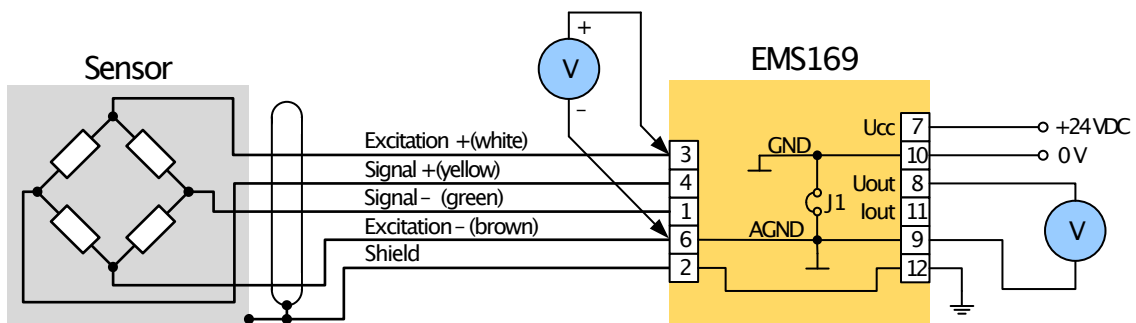

Fig. 9. Excitation sensor voltage measuring (with sensor)

5. **Sensor resistance test**. If the sensor voltage excitation without sensor (test 3) is OK and the voltage with sensor is smaller, the sensor is probably damaged. Measure the resistant of the sensor according to figure 10. The right value is in the datasheet of the sensor, usually between $370 \text{ } \Omega$ and $400 \text{ } \Omega$.

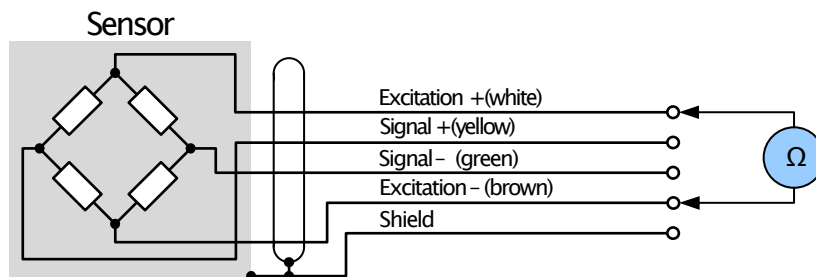

Fig. 10. Sensor resistance test

6. **Sensor overload.** Overload of the sensor is a frequent failure and it is characterized by an increase in output voltage of the unloaded sensor. The output voltage can be measured in the circuit shown in fig. 11.

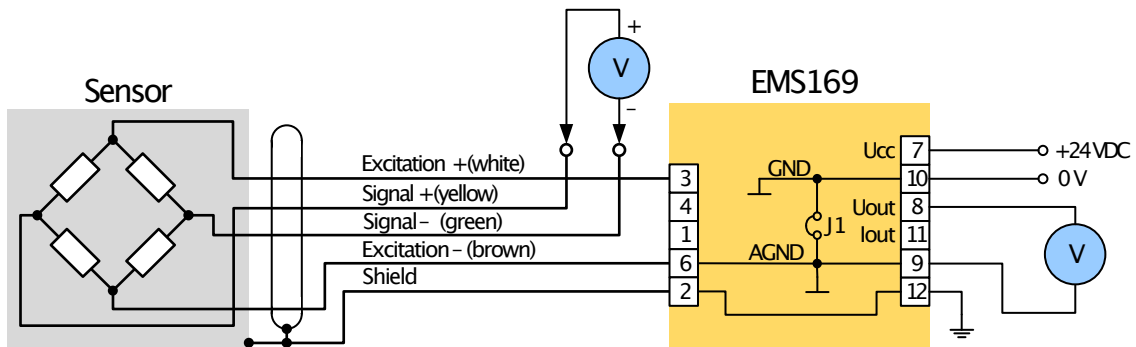

Fig. 11. Sensor output voltage measuring

To evaluate of the measurement results, it is necessary to know the sensor parameters and correctly calculate them. For example, consider sensor series EMS20 with a nominal sensitivity of 1.5 mV / V and with a zero balance of 2% F.S. The sensor supply voltage on the EMS169 is 7V. The maximum output voltage for unloaded sensor is calculated by formula:

$$U_{out} = 1,5 \cdot 7 + 0,14 = 10,55 \text{ mV}$$

If the measured voltage is greater than + 0.21 mV or less than – 0.21 mV, the sensor was overloaded and the only way to correct it is to replace it. It is also possible to check the function of the sensor by pushing it by hand or by a tool (be careful of the range of the sensor to avoid damage). The voltage should be varied, the magnitude depends on the range of the sensor and the pushing force.