

SHEAR-WEB FORCE SENSOR WITH BUILT-IN SIGNAL CONDITIONER MEG41



Special features

- Mechanical design identical to **MEG40** type
- Strain gauge measuring system
- Tension / Compression
- Built-in signal conditioner with voltage and current output
- Possibility to use both outputs simultaneously
- Power supply: 5 ... 27 VDC

The MEG41 sensor is used for force measuring in the direction of compression and tension. It has a built-in electronic signal conditioner which provides all standard output ranges, both voltage and current. It is also possible to use both outputs simultaneously. The sensor is particularly suitable for measuring forces on machines.

Overview of models

Model	Output (Vout, Iout)	Power supply (Vcc)
MEG41 – U(0.5 ... 4.5)	0.5 ... 4.5 V	5 ... 27 VDC
MEG41 – U(2.5 ± 2)	2.5 ± 2 V	5 ... 27 VDC
MEG41 – U(2 ... 10)	2 ... 10 V	11.5 ... 27 VDC
MEG41 – U(6 ± 10)	6 ± 4 V	11.5 ... 27 VDC
MEG41 – I(4 ... 20)	4 ... 20 mA	22 ... 27 VDC
MEG41 – I(12 ± 8)	12 ± 8 mA	22 ... 27 VDC

The version of the output as well as the range of the sensor and the direction of the load must be specified in the order. After the setting in the factory, it is no longer possible to change these parameters.

It is possible to use both voltage and current output simultaneously during operation. However, it is practical used only for the output 2 ... 10 V / 4 ... 20 mA or 6 ± 10 V / 12 ± 8 mA and the supply voltage 24 V. With other voltage outputs and smaller supply voltage, the current output is limited.

The adjustment of the sensor (within the permitted tolerances) is only possible for one output (either for voltage or for current). The output specified in the order is set.

Specifications

Parameter	Value		Unit
Rated capacity (F_n)	1, 2, 5	10, 20, 50	kN
Overload			
- <i>Safe</i>	130		% F_n
- <i>Ultimate</i>	150		% F_n
- <i>Permanent static load (recommended value)</i>	75		% F_n
- <i>Dynamic load (recommended value)</i>	50		% F_n
Output tolerance			
- <i>Voltage output</i>	± 80		mV
- <i>Current output</i>	± 0.16		mA
Output load impedance			
- <i>Voltage output (min)</i>	2		k Ω
- <i>Current output (max)</i>	500		Ω
Cut-off frequency of built-in amplifier (-3 dB)	200		Hz
Max error			
- <i>Non-linearity</i>	0.25	0.5	% F.S.
- <i>Hysteresis</i>	0.25	0.5	% F.S.
Temperature range			
- <i>Nominal</i>	0 ... + 50		$^{\circ}\text{C}$
- <i>Operating</i>	- 10 ... + 50		$^{\circ}\text{C}$
Temperature drift			
- $\Delta V_{out} / \Delta T$ (max)	± 1.5		mV / $^{\circ}\text{C}$
- $\Delta I_{out} / \Delta T$ (max)	± 3		$\mu\text{A} / ^{\circ}\text{C}$
Power supply (V_{cc})			
- <i>Range</i>	5 ... 27		VDC
- <i>Current consumption (max)</i>	40		mA
Power supply drift ($V_{cc} = 5$ V or 24 V)			
- $\Delta V_{out} / \Delta V_{cc}$ (max)	± 20		mV / V
- $\Delta I_{out} / \Delta V_{cc}$ (max)	± 40		$\mu\text{A} / \text{V}$
Connection cable 1, 2, 5, 10, 20 kN			
- <i>Type</i> ¹	LifYDY 7x0.05		
- <i>Length</i>	2		m
- <i>Outer diameter</i>	4.5		mm
Connection cable 50 kN			
- <i>Type</i> ¹	LifYDY 7x0.1		
- <i>Length</i>	2		m
- <i>Outer diameter</i>	4.7		mm
Protection	IP54		

¹ Only 4 wires are used

How to order

Common formula for ordering:

MEG41-U/I(output range) – force range – load direction

- Sensor type with type of output:
 - MEG41-U – voltage output
 - MEG41-I – current output

- Voltage output ranges:
 - 0.5 ... 4.5 V
 - 2.5 ± 2 V (zero shifted to 2.5 V)
 - 2 ... 10 V
 - 6 ± 4 V (zero shifted to 6 V)

- Current output ranges:
 - 4 ... 20 mA
 - 12 ± 8 mA (zero shifted to 12 mA)

- Measured force range (kN):
 - 1 kN, 2 kN, 5 kN, 10 kN, 20 kN, 50 kN

- Load direction:
 - Compression
 - Tension
 - Compression/Tension (both)

Examples:

2 kN sensor with voltage output 2 ... 10V, load direction compression, order:

MEG41-U (2 ... 10V) – 2 kN – Compression

10 kN sensor with current output with shifted zero, load direction Compression and Tension, order:

MEG41-I (12 ± 8 mA) – 10 kN – Compression/Tension

Outline dimensions

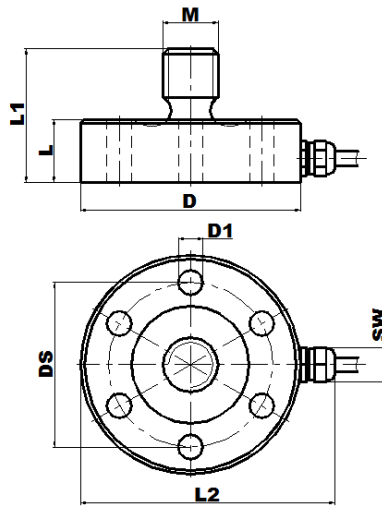

Rated capacity F_n (kN)	D mm	D1 mm	L mm	L1 mm	L2 mm	M mm	SW mm	DS mm	Mass kg	Deflection, @ F_n (μm)	Body material
1	38	6x4.2	11	22	46	M8	$\Phi 4$	30	0.07	30	Stainless steel
2	38	6x4.2	11	22	46	M8	$\Phi 4$	30	0.07	30	
5	38	6x4.2	11	22	46	M8	$\Phi 4$	30	0.08	35	
10	50	6x5.2	14	29	58	M10	8	38	0.18	45	
20	56	6x6.3	16	34	64	M14	8	42	0.27	50	
50	68	6x8.4	19	42	76	M20	11	50	0.50	65	

Recommended installation

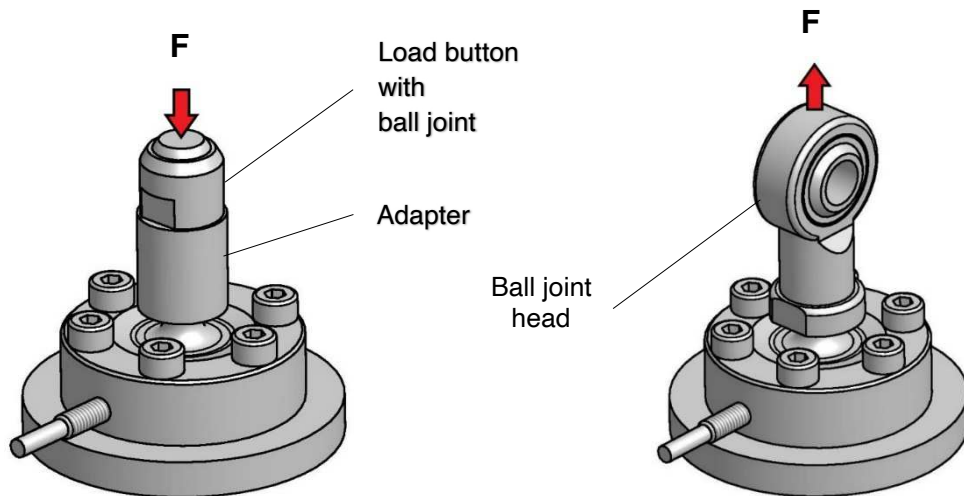

Direction of load COPRESSION

Direction of load TENSION

Installation notes:

- The force must only act in the axis of the sensor.
- The sensor must be built in such a way that the force acts only through the threads. Adapter or the ball joint head must not touch the sensor body itself.

Wiring diagram

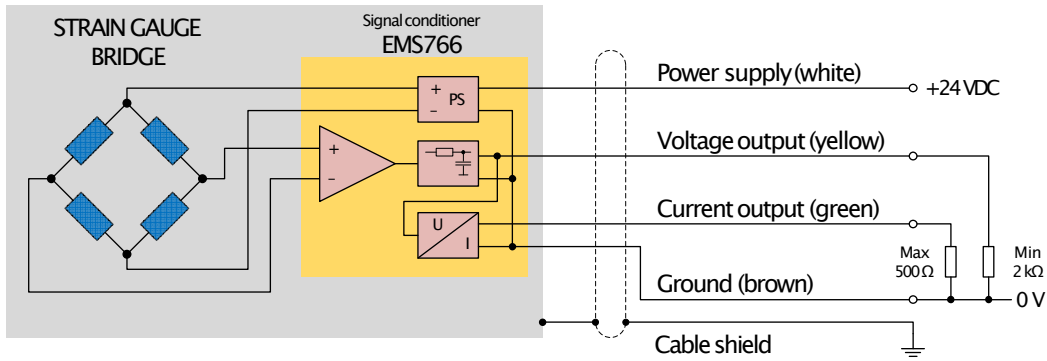

Output characteristics

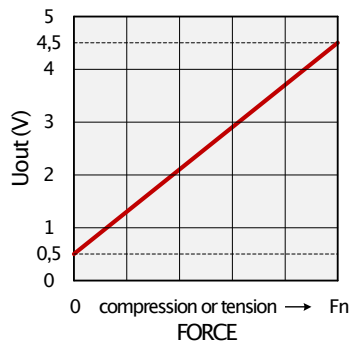

$U(0.5 \dots 4.5 \text{ V})$

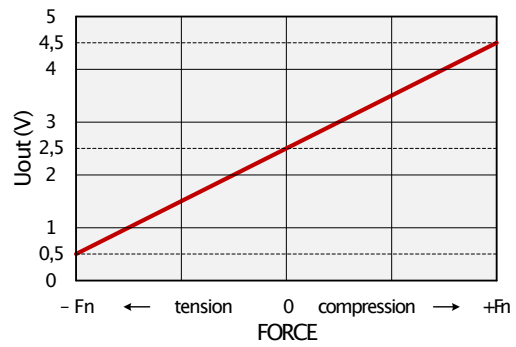

$U(2.5 \pm 2 \text{ V})$
zero shifted to 2.5 V

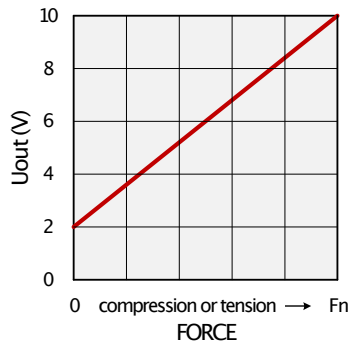

$U(2 \dots 10 \text{ V})$

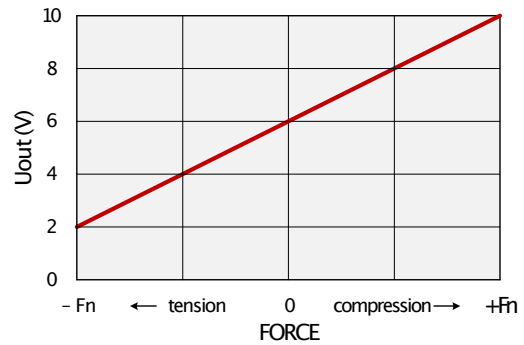

$U(6 \pm 4 \text{ V})$
zero shifted to 6 V

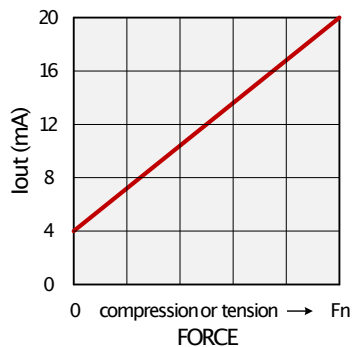

$I(4 \dots 20 \text{ mA})$

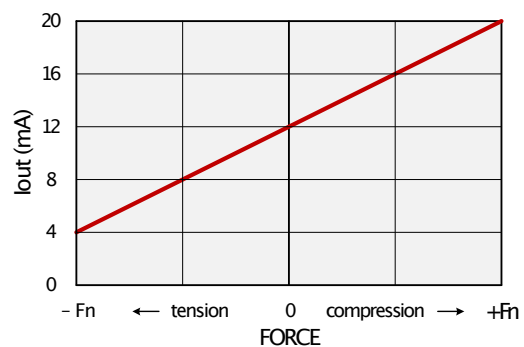

$I(12 \pm 8 \text{ mA})$
zero shifted to 12 mA