

### Special features



- Mechanical design identical to **MEG50** type
- Direction of load COMPRESSION / TENSION
- Built-in signal conditioner with voltage or current output
- Model of sensor:
  - **MEG51- U** – with voltage output
  - **MEG51- I** – with current output
- Power supply: + 5 ... + 24 VDC

### Specifications

Rated capacity (F <sub>n</sub> )	0.1; 0.2; 0.5 1; 2; 5	10; 20; 50	100; 200; 500	kN
Overload				
- Safe	130			% F <sub>n</sub>
- Ultimate	150			% F <sub>n</sub>
- Permanent static load <sup>1</sup>	75			% F <sub>n</sub>
- Dynamic load <sup>1</sup>	50			% F <sub>n</sub>
Voltage output (model <b>MEG51-U</b> ) <sup>2,3,5</sup>				V
- Standard (V <sub>SUP</sub> = 5 V)	2.5 ... 4.5			V
- Standard (V <sub>SUP</sub> = 24 V)	2 ... 10			V
Min. load impedance	20			kΩ
Current output (model <b>MEG51-I</b> ) <sup>2,4,5</sup>				mA
- Standard (V <sub>SUP</sub> = 24 V)	4 ... 20			mA
Max. load impedance	500			Ω
Power Supply (V <sub>SUP</sub> )				VDC
- Range	4.9 ... 27			VDC
- Current consumption (Max)	40			mA
Cut – off frequency (– 3 dB)	0 ... 200			Hz
Max error				% F.S.
- Non-linearity	0.25	0.5	1.0	% F.S.
- Hysteresis	0.25	0.5	1.0	% F.S.
Temperature effect				% F.S./10 °C
- On zero	0.15			% F.S./10 °C
- On output	0.15			% F.S./10 °C

#### Notes:

- 1 Recommended value
- 2 The sensor has only voltage or current output.
- 3 At the voltage output, the supply voltage of the sensor must be at least 0.5 V higher than the maximum output voltage (V<sub>SUP</sub> ≥ V<sub>UT\_MAX</sub> + 0.5 V).
- 4 For current output, the sensor supply voltage must be in the range V<sub>SUP</sub> = 12 ... 27 V
- 5 After agreement with the manufacturer, it is possible to set another output.

## Operating conditions and design

Temperature range - <i>Nominal</i> - <i>Operating</i>	0 ... + 50 - 10 ... + 50	°C °C
Protection	IP54	
Body material - <i>0.1; 0.2; 0.5 kN</i> - <i>1; 2; 5; 10; 20; 50; 100; 200; 500 kN</i>	Aluminium Stainless steel	
Cable <sup>4</sup> - <i>Type</i> - <i>Length</i>	LifYDY 7 x 0.05 2	m

Notes:

6 Only 3 wires are accessible, the others are for factory settings used

## How to order

Common formula for ordering: **MEG51-U/I(signal conditioner output range) – force range**

- Sensor type with type of output:
  - **MEG51-U** – voltage output
  - **MEG51-I** – current output
- Signal conditioner voltage output types:
  - 2.5 – 4.5 V
  - 2 – 10 V
- Signal conditioner current output types:
  - 4 – 20 mA
- Measured force range (kN): 0.1; 0.2; 0.5; 1; 2; 5; 10; 20; 50; 100; 200; 500

20 kN sensor with voltage output 2 – 10V example:

**MEG51-U (2 – 10V) – 20kN**

50 kN sensor with current output 4 – 20 mA example:

**MEG51-I (4 – 20mA) – 50kN**

---

## Outline dimensions

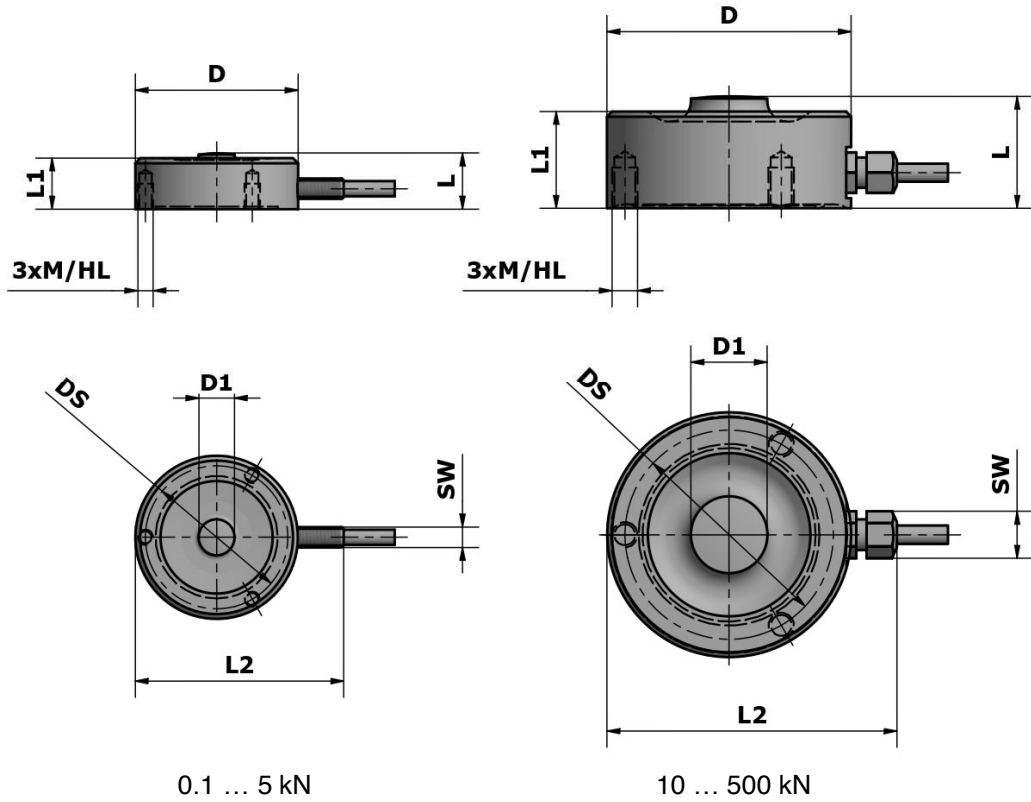

$F_n^1$ (kN)	Dimensions in mm									
	D	DS	D1	L	L1	L2	SW	M / HL	Mass kg	Deflection @ $F_n$ ( $\mu$ m)
0.1	32	28	7	11	10	40	$\Phi 4$	M3 / 5	0.04	30
0.2	32	28	7	11	10	40	$\Phi 4$	M3 / 5	0.04	30
0.5	32	28	7	11	10	40	$\Phi 4$	M3 / 5	0.04	30
1	32	28	7	11	10	40	$\Phi 4$	M3 / 5	0.07	30
2	32	28	7	11	10	40	$\Phi 4$	M3 / 5	0.07	30
5	32	28	7	11	10	40	$\Phi 4$	M3 / 5	0.07	30
10	36	32	8	16	15	44	8	M3 / 5	0.10	50
20	40	35	10	19	17	50	8	M4 / 6	0.14	50
50	48	41	15	22	19	58	8	M5 / 8	0.22	60
100	60	50	20	26	22	70	11	M6 / 10	0.43	100
200	74	61	28	31	26	84	11	M8 / 12	0.80	100
500	110	87	44	42	36	120	11	M10 / 16	2.50	150

## Recommended installation

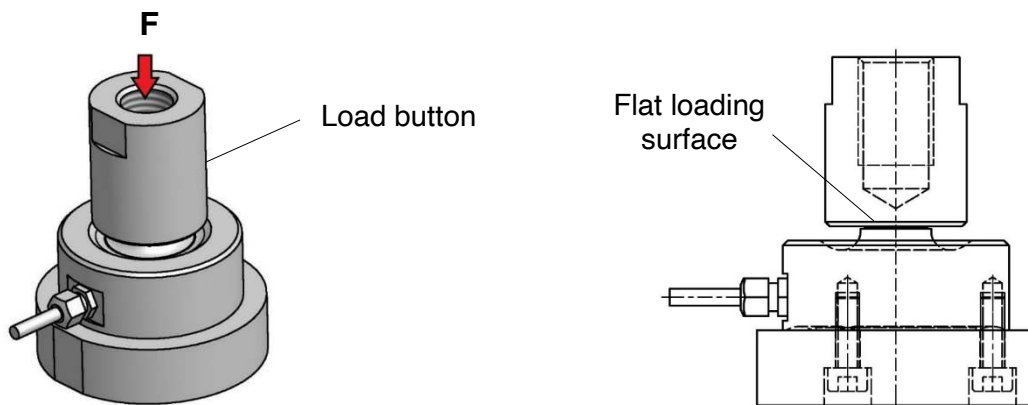

## Wiring diagram MEG51 - U, voltage output

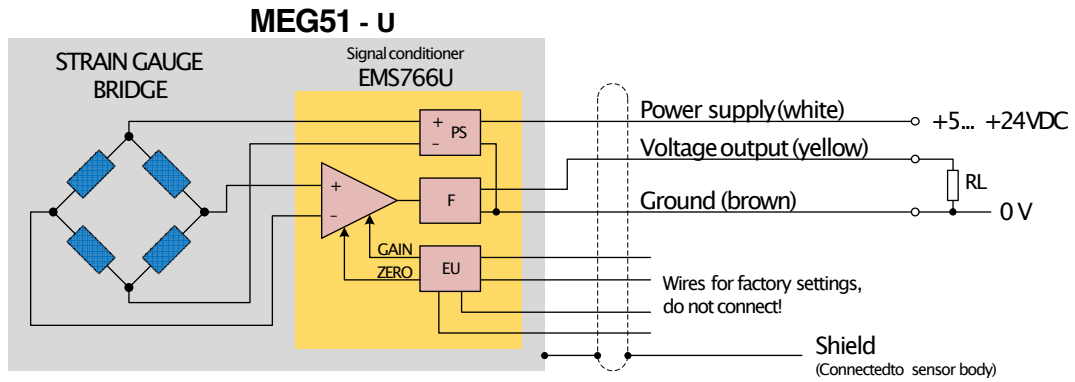

## Output characteristics, voltage output

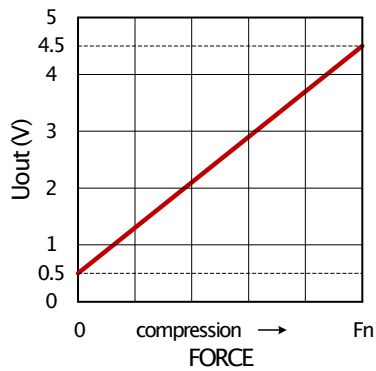

Output 2.5 ... 4.5 V

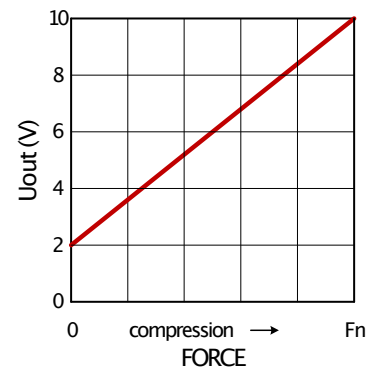

Output 2 ... 10 V

## Wiring diagram MEG51 - I, current output

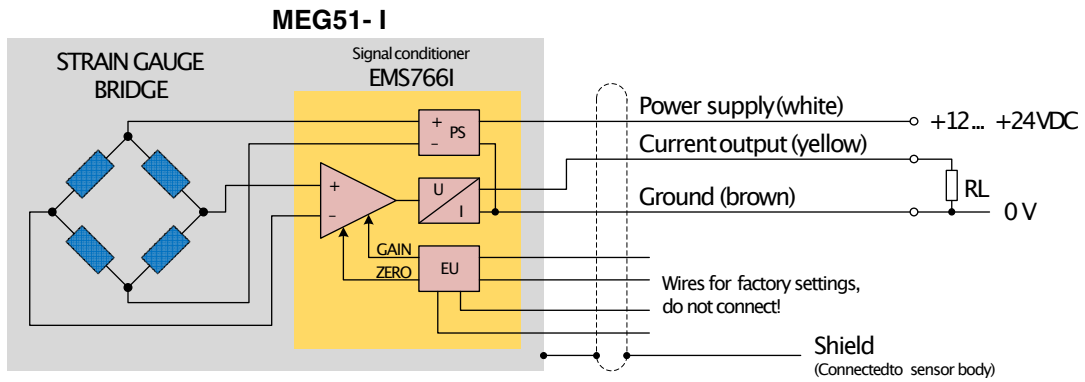

## Output characteristic, current output

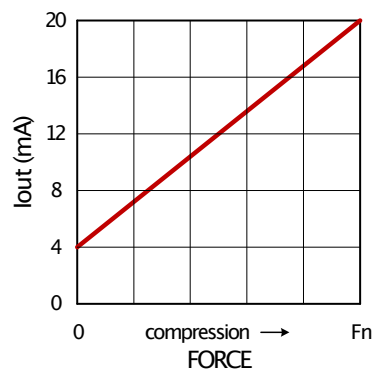

Output 4 ... 20 mA