



- Optical measurement
- Measuring lengths from 50 mm to 1500mm
- High resolution up to 1 μ m
- $\pm 10\mu$ m accuracy
- 5 ball bearing system
- Single seal protection
- 5 VDCTTLquadrature or 1vpp sinusoidal output signal
- Easy mounting
- 60 m/min traveling speed

ALS series optical linear encoder systems are protected from factors such as dust, shavings, dirt and coolant with its compact design. ALS5 series, which has optical measuring principle with glass ruler, can measure between 50 and 1500mm.

APPLICATIONS

- Manuel Benches
- Press Brakes and Bending Machines
- Robotic / Material Packaging
- Linear Bearing Systems
- Automation and Robotic Applications
- Textile Machinery
- Transfer Machines
- Turning, Milling
- Woodworking machines etc.

TECHNICAL FEATURES

Measuring Type	Optical	Reference Mark	1 reference mark at every 50 mm
Measuring Lengths	Different lengths from 50 mm to 1500 mm	Body Material	Aluminum
Resolution	1 μ m, 5 μ m or 1Vpp sinusoidal	Operating Temperature	0°C..50°C
Signal Period	20 μ m	Storage Temperature	-20°C..70°C
Accuracy	$\pm 10\mu$ m	Protection Class	IP54
Repeatability	± 1 pulse	Electrical Connection	Spiral cable and socket (For TTL Signal: D-SUB 9 pin male socket / For Sinus Signal: M16/8 pin female socket)
Max traveling speed	60m/min		
Supply Voltage	5 VDC	Max cable length	50-500mm(3m armoured cable) 600-2000mm(5m armoured cable)
Output Type	5V TTL or 1Vpp Sinusoidal		

ELECTRICAL CONNECTIONS

PIN NO	CABLE COLOR	D-SUB9 PIN SOCKET	M16/8 PIN FEMALE SOCKET
		TTL SIGNAL	SINUS SIGNAL
1	WHITE	A	0°
2	BROWN	/B	180°
3	RED	+5VDC	+5VDC
4	BLACK	0V-GND	0V-GND
5	BLUE	/A	90°
6	GREEN	B	270°
7	YELLOW	/Z	Z
8	GREY	Z	N/C

In the table, the cable colors of sensors output signals are given. If the control circuit is suitable, in the line driver sensors, the not signals (/A, /B, /Z) have to be added to the system. If it is not suitable /A, /B, /Z signal cables must be fixed as insulated separately. Don't forget that these edges have electricity too.

MECHANICAL DIMENSIONS

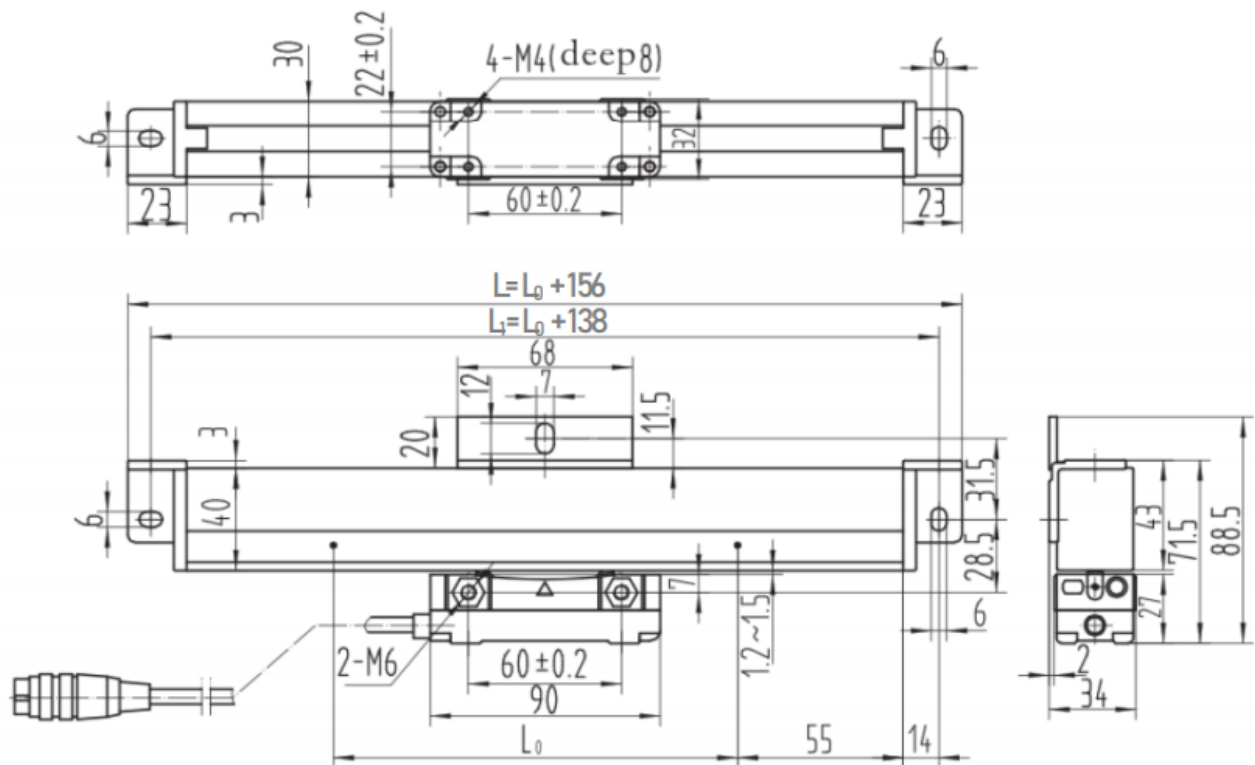

L_0 : Measuring Length (mm) (Different lengths from 50 to 1500 mm)

L_1 : Distance between mounting holes (mm)

L : Body Length (mm)

ORDER CODE

Model				Measuring Length
ALS 5	-	XX	-	Different lengths from 50 mm to 1500 mm
				Resolution
				01: 1 μ m
				05: 5 μ m
				S : Sinusoidal