



- Easy mounting
- "Slim Line" type aluminum carrier body
- Magnetic tape integrated in profile
- Protection class IP67
- Resistant to humidity
- Stainless steel cover strip

The highly rugged, flexible plastic magnetic tape can be applied to a machine tool easily. With a special industrial adhesive layered strip, B5 or B2 Magnetic Tape can be attached to the overside of the profile system.

The magnetic material is magnetised in defined and even distances and works as a solid measure. The magnetic scale retains its firmness by means of a spring steel base.

Technical Specifications	
Operating temperature	-25 to +85°C
Pole pitch	5 mm, 2 mm
Accuracy Class	±40µm /m or ±20µm/m
Storage temperature	B5 (-40°C to +120°C B2)
Body Material	Anodized Aluminum
Protection Class	IP67

The Magnetic Sensors That Can Be Used With PS 200 Series Profiles

- MLS 110
- MLS 120
- MLS 130
- MLS 210



Order Code

Model

PS 210
PS 220
PS 230

XX XXX

Measurement Distance

Optional, 50 mm to 100 meters
(Ex: 300 mm)

XXX

Magnetic Tape

B5
B2

XX

WARNING (!) The proximity of the band with comparator, magnet or similar instruments having a magnetic effect, disrupts the working structure of the band. The product should be kept away from devices that generate this type of magnetic field.

PS 210 –Mechanical Dimensions



PS 210

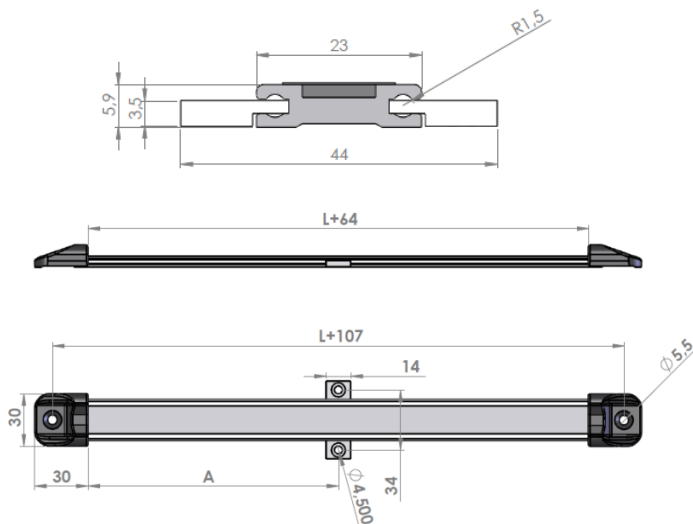

PS 220 –Mechanical Dimensions



PS 220

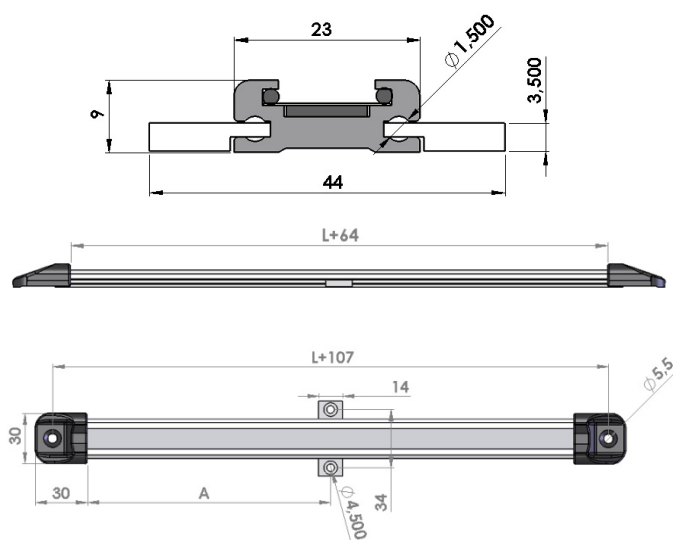

PS 230 –Mechanical Dimensions



PS 230

