

TRANSMITTER FOR PRESSURE AND TEMPERATURE ATM/T



Features

- Compact and robust stainless steel assembly 1.4435 (316L)
- Piezoresistive and Pt 100 measuring element
- Gauge, absolute or sealed gauge
- Standard DIN pressure ranges from 0...100 mbar to 0...1000 bar
- Calibration available for all common pressure units
- Complies with the EMC directive 89/336/EEC
- High reliability
- Short delivery time
- Customized versions due to modular assembly
- Available as level or flange transmitter
- Reverse polarity and short circuit protected
- Media temperature up to 150°C (optional)

Typical applications

- Machine installations
- Industrial process control
- Heating and ventilation
- Environmental monitoring
- Food industry
- Mobile hydraulics
- Test and calibration systems

Ordering Information

26 X . XXXX . XXXX . XX . XXX

Type	ATM/T	26				
Pressure type	Gauge	1				
	Absolute	2				
	Sealed gauge	3				
Pressure range	0...100 mbar		00			
	0...160 mbar		01			
	0...250 mbar		02			
	0...400 mbar		03			
	0...600 mbar		04			
	0...1.0 bar		05			
	0...1.6 bar		06			
	0...2.5 bar		07			
	0...4.0 bar		08			
	0...6.0 bar		09			
	0...10 bar		10			
	0...16 bar		11			
	0...25 bar		12			
	0...40 bar	3	13			
	0...60 bar	3	14			
	0...100 bar	3	15			
	0...160 bar	3	16			
	0...250 bar	3	17			
	0...400 bar	3	18			
	0...600 bar	3	19			
0...1000 bar	3	20				
Special calibration			99			
Temp. measuring range	-25...100°C (standard)					
	customized temperature measurement range					
Process connection	G 1/2 M, frontal diaphragm (Fig. 5)				14	
	G 1/2 M, flush diaphragm (Fig. 6)				15	
	Special process connection				99	
Electrical connection	Connector DIN 43650 (screwed on ¹⁾) ²⁾ (Fig. 10) IP 65					01
	Connector Binder 723, 5-pin ²⁾ (Fig. 11) IP 67					03
	Connector Binder 723, 5-pin (screwed on ¹⁾) ²⁾ (Fig. 12) IP 67					43
	Connector MIL C26482, (10-6) ²⁾ (Fig. 13) IP 40					06
	PE cable ³⁾ 4) (Fig. 14) IP 67					13
	PUR cable ³⁾ (Fig. 14) IP 67					15
	Teflon cable ³⁾ (Fig. 14) IP 67					21
	Special electrical connection					99
Output signal	0... 5 V DC					46
	0...10 V DC					47
	0...20 mA					00
	4...20 mA					05
	Special output signal					99
Accuracy	Pressure	Temperature				
	≤ ±0.5 % FS	according to data sheet				0
	≤ ±0.25% FS	according to data sheet				1
	≤ ±0.1 % FS (on request)	according to data sheet				2
Temperature range	Compensated 0...70°C (media temperature 0... 80°C)					0
	Compensated -25...85°C (media temperature -25...100°C)					1
	Compensated -25...85°C (media temperature -25...150°C)					2
	Special temperature range					9
Options	Electronics packed in: Gauge pressure					C
	Absolute and sealed gauge pressure					D
	Special oil filling: ASEOL Food					G
	Halocarbon					H
	Seals: EPDM					S
	Kalrez					T
Special options						Z

¹⁾ Zero offset and span adjustable

²⁾ Cable socket connector not included

³⁾ Please specify the required cable length

⁴⁾ Suitable for drinking water (food approved)

Specifications

Pressure range	[bar]	0.1 ... 0.5	> 0.5 ... 2	> 2 ... 25	> 25 ... 600	> 600 ... 1000
Overpressure		3 bar	3 x FS (min. 3 bar)	3 x FS	3 x FS (max. 850 bar, optional 1500 bar)	1500 bar
Burst pressure	[bar]	≥ 30	≥ 30	3 x FS (min. 25)	> 850 (optional 1500 bar)	1500
Accuracy¹⁾	[± % FS]	≤ 0.5 (optional ≤ 0.25)	≤ 0.5 (optional ≤ 0.25, ≤ 0.1)	≤ 0.5 (optional ≤ 0.25, ≤ 0.1)	≤ 0.5 (optional ≤ 0.25, ≤ 0.1)	≤ 1 (optional ≤ 0.5, ≤ 0.25)
Thermal shift	[± % FS/°C]					
Zero	0...70°C	0.06	0.03	0.015	0.015	0.015
	-25...85°C	0.08	0.04	0.02	0.02	0.02
Span	0...70°C	0.015	0.015	0.015	0.015	0.015
	-25...85°C	0.02	0.02	0.02	0.02	0.02
Response time		< 1 ms/10...90% FS				
Long term stability (1 year)		< 4 mbar	< 4 mbar	< 0.2% FS	< 0.2% FS	< 0.2% FS

¹⁾ Zero based non-conformity according to DIN 16086, including hysteresis and repeatability

Temperature measuring range

Temperature measuring range	-25...100°C
Optional measuring ranges:	on request
lower range limit	-50°C
upper range limit	150°C
Accuracy (probe, electronics, adjustment):	±2°C

Output signal	4 ... 20 mA	0 ... 20 mA	0 ... 5V / 0 ... 10 V
Type	Current transmitter	Current transmitter	Voltage transmitter
Supply voltage (U_b)	15...30 V DC	15...30 V DC	15...30 V DC
Supply voltage influence	< 0.1% FS	< 0.1% FS	< 0.1% FS
Circuit diagram			
Load resistance	$(U_b - 5V) / 0.02A$	$(U_b - 5V) / 0.02A$	$R_L > 10k\Omega$
Load resistance influence	< 0.1% FS	< 0.1% FS	< 0.1% FS

Materials

Process connection, diaphragm, housing	Stainless steel 1.4435 (316L)	(other materials on request)
Seals (standard)	Viton	(other materials see ordering information)

Electromagnetic compatibility

Standard	Level	Typical interferences	
Emission:			
EN 50081-1:1992	Generic emission standard		
EN 55022:1994	Emission, class B		
Immunity:			
EN 50082-2:1995	Generic immunity		
EN 61000-4-2:1995	Electrostatic discharge	4kV contact, 8kV air	
ENV 50140:1993	Radiated electro-magnetic field	10V/m, 80-1000 MHz, 80% AM 1kHz	Cellular phones, radio sets
ENV 50204:1995	Radiated electro-magnetic field (GSM)	10V/m, 950 MHz, 200Hz on/off	Digital portable phones
EN 61000-4-4:1995	Fast transients (burst)	2 kV	Motors, valves
ENV 50141:1993	Conducted radio-frequency	10V, 0.15-80 MHz, 80% AM 1kHz	Cellular phones, radio sets



The pressure transmitter ATM fulfill the emission and immunity requirements described in the EMC directive 89/336/EEC.

Pressure Connection

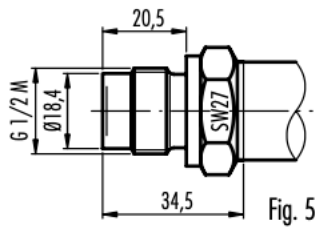

Fig. 5

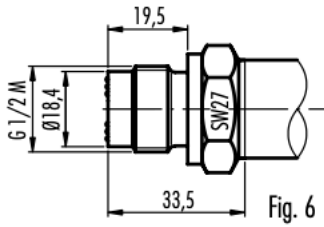
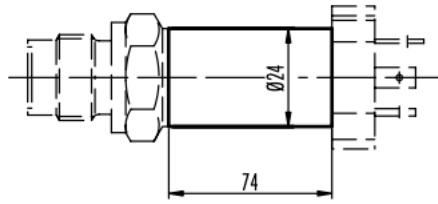

Fig. 6

Dimensions

Version for media temperature up to 100°C



Version for media temperature up to 150°C

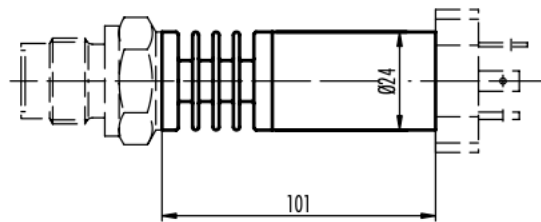

Electrical Connection

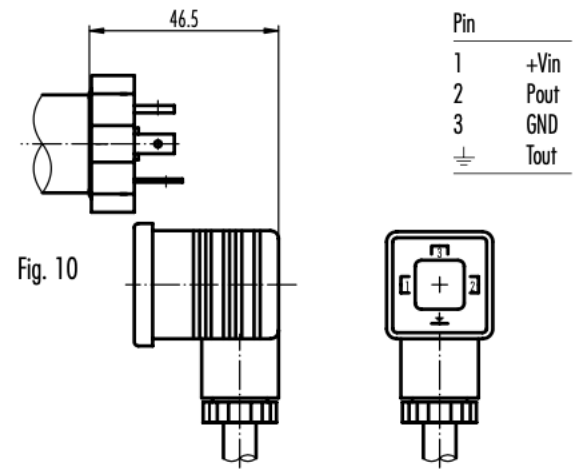

Fig. 10

Pin	
1	+Vin
2	Pout
3	GND
⊥	Tout

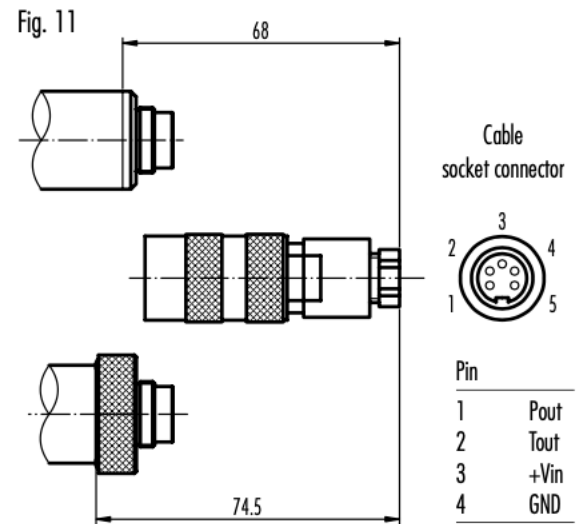

Fig. 11

Cable socket connector

Pin	
1	Pout
2	Tout
3	+Vin
4	GND

Fig. 12

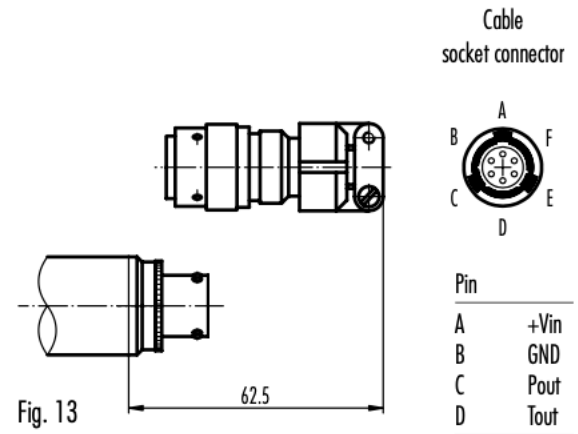

Fig. 13

Cable socket connector

Pin	
A	+Vin
B	GND
C	Pout
D	Tout

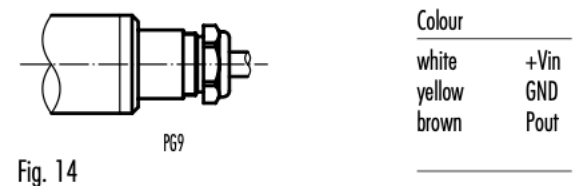

Fig. 14

Colour	
white	+Vin
yellow	GND
brown	Pout



BP 501 - Juvigny
F-74105 ANNEMASSE Cedex
Tél. +33 (0)4 50 87 78 64
Fax +33 (0)4 50 87 78 46
E-mail : info@scaime.com



SIREN 389 325 283 RCS Thonon-les-Bains

Agent

MEGATRON, s.r.o.

Mrštíkova 16, 100 00 Praha 10

T.: 274 780 972, info@megatron.cz

www.megatron.cz

SCAIME se réserve le droit d'apporter toutes modifications sans avis préalable.

FT-ATMT-E-0109