

DMMST Non-Contact Magnetostrictive Position Sensor

EtherCAT 

- Measuring length 100–5000mm
- EtherCAT protocol
- 24 VDC power supply



Technical Specifications

Measurement stroke	100 – 5000 mm
Resolution	25µm (100mm–400mm), 50µm (450mm–3000mm), 100µm (4000mm–5000mm)
Repeatability	100 µm
Output	EtherCAT
Power supply	24 VDC ±10%
Displacement speed	max. <5m/s
Max. consumption	<100mA (depending on stroke length)
Linearity	Up to ±0,05% full scale (min.100µm)
Reverse polarity protection	Up to –30 VDC
Overvoltage protection	Up to +30VDC
Update time	0,5 ms up to 1000 mm 0,8 ms up to 2000 mm
Interface	EtherCAT Ethernet Control Automation Technology
Protocol	EtherCAT 100Base-Tx Fast Ethernet
Data-length	16 bit
Data transmission rate	100 Mbit/s max.
PDO (Process data object)	1A00 TxPDO mapping PDO content 0x600:01 position value
Diagnostic LEDs	Green led: Power on, Bus communication active Red led: Error, stop mode
Protection level	IP 65
Operating temperature	–20°C ... +80°C
Storage temperature	–30°C ... +90°C

Mechanical Specifications

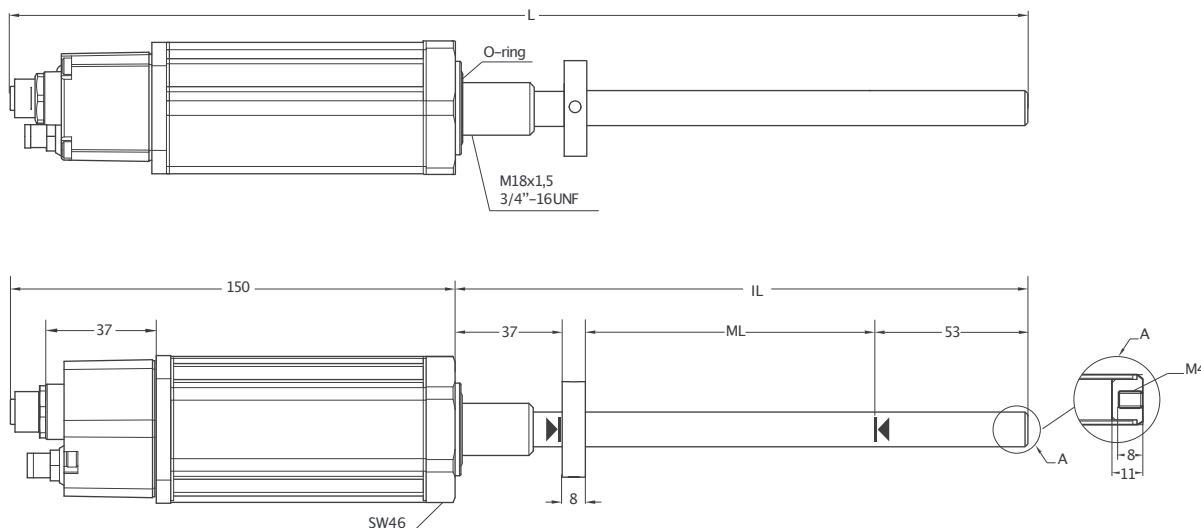

DMMST (mm)	100	150	200	250	300	350	400	450	500	550	600	650	700	750	800	850	900	1000	1100	1200	1300	1400	1500	1750	2000	2250	2500	3000	4000	5000							
ML (Measuring Length)	100	150	200	250	300	350	400	450	500	550	600	650	700	750	800	850	900	1000	1100	1200	1300	1400	1500	1750	2000	2250	2500	3000	4000	5000							
IL (Installation Length)	198	248	298	348	398	448	498	548	598	648	698	748	798	848	898	948	998	1098	1198	1298	1398	1498	1598	1848	2211	2461	2711	3211	4211	5211							
(Total Length)	348	398	448	498	548	598	648	698	748	798	848	898	948	998	1048	1098	1148	1248	1348	1448	1548	1648	1748	1998	2333	2583	2833	3333	4353	5353							
Dead Zone Calculation																	37/53 mm																				

Connection

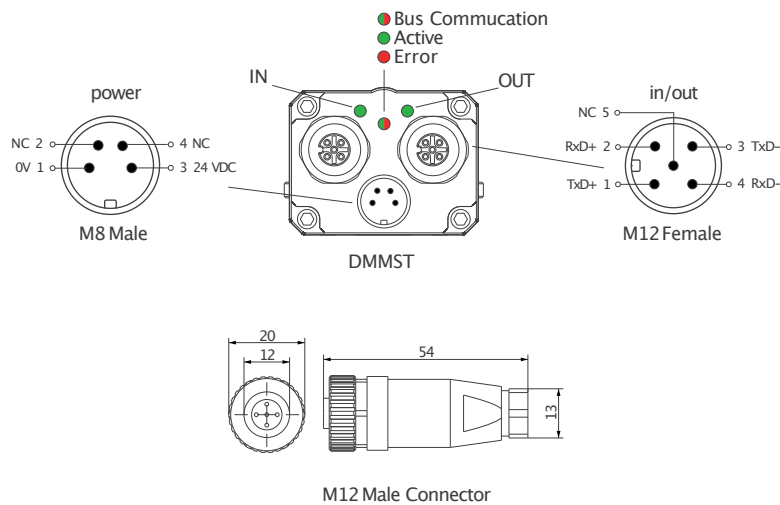

Cursor

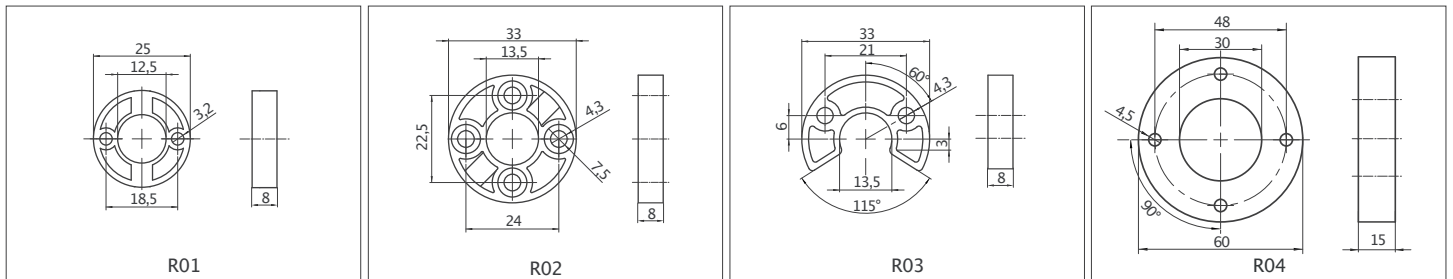

Ordering Procedure

Model	Measurement stroke	Rod & Thread	Sealing surface	Protocol	Cursor	Dead zone
DMMST	150	E12	S	ETN	1R02	37/53
DMMST	100 – 5000 mm	E10: Ø10, M18x1,5 E12: Ø12, M18x1,5 U10: Ø10, 3/4"–16UNF U12: Ø12, 3/4"–16UNF EO10: Ø10, M24x1,5 EO12: Ø12, M24x1,5 EA10: Ø10, M24x1,5 EA12: Ø12, M24x1,5 EB10: Ø10, M30x2 EB12: Ø12, M30x2	S: O-ring F: Flat	ETN: EtherCAT	1R01: 25 mm 1R02: 33 mm 1R03: 33 mm 1R04: 60 mm 1R01: 1 cursor 2R01: 2 cursors	≤2000 mm 30/53 37/53 47/53 57/53 67/53 77/53 30/60 51/63 >2000–3000 mm 130/53 >3000–5000 mm 150/53